

NOMINAL DIAMETAR DN	MAX. WORK PRESSURE For NP 6 (bar)	TESTING PRESSURE bar	
		BODY	CLOSING
40 – 250	6	10	6

VERSION D – body: bronze; internal parts: brass or bronze

VERSION G – body: cast steel; internal parts: brass

VERSION H – body: GGG; internal parts: brass or bronze

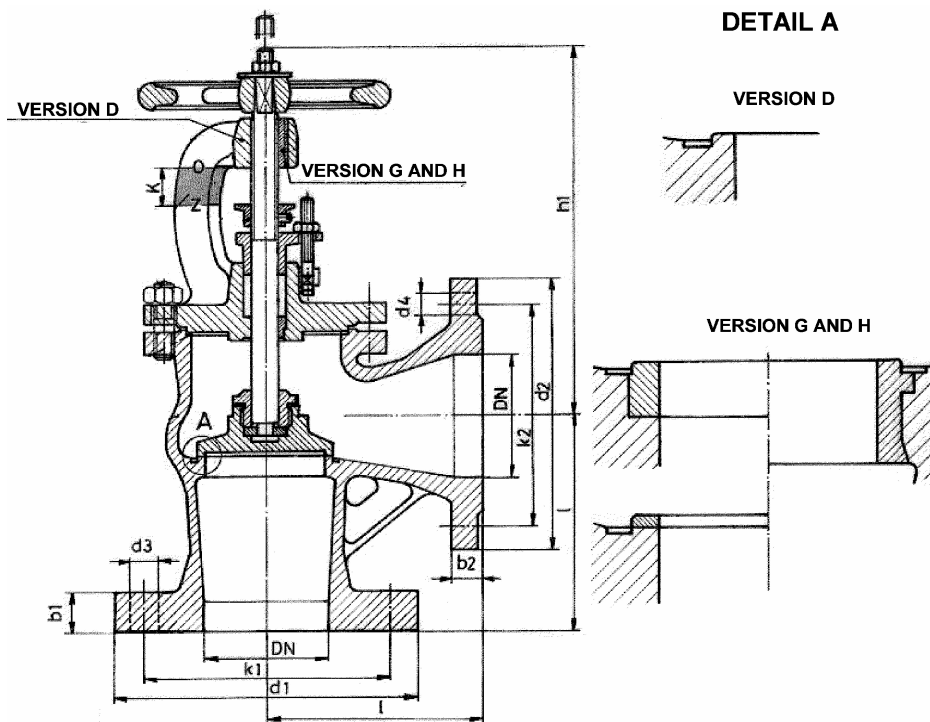

NOMINAL DIAMETAR DN	FLANGE NP 16						FLANGE NP 6						MAIN MEASURES		WEIGHT ~ kg		
	d ₁	b ₁ VERSION		DRILLING			d ₂	b ₂ VERSION		DRILLING			L	h ₁ ~	D	G i H	
		D	G i H	k ₁	d ₃	n .		D	G i H	k ₂	d ₄	n .					
40	150	14	16	110	18	4	130	14	14	100	14	4	115	199	8,91	9,26	
50	165	16	18	125			140			110			125		10,08	11,3	
65	185			145			160			130			145		229	14,8	15,0
80	200	18	20	160			16	16	150	18			18		175	8	200
100	220	20	22	180	210	170			155		261	26,7		29,0			
125	250			210	240	200			225		297	26,7		29,0			
150	285	22	24	240	20	20	265	20	20		225	12		8	200		378
175	315			270			295			255	275		410		66,9	69,5	
200	340			295			320			280	275		464		83,7	86,7	
250	405	26	26	355	26	12	375			22	22		335		325	532	