

STRAIGHT VALVE, SCREW DOWN OF CAST STEEL NP16

Type 11085

NOMINAL DIAMETAR DN	NOMINAL PRESSURE NP	TESTING PRESSURE bar		MAX. WORK PRESSURE For liquid, gas and steam bar	
		BODY	CLOSING	To 120°C	To 400°C
15 - 200	16	25	16	16	14

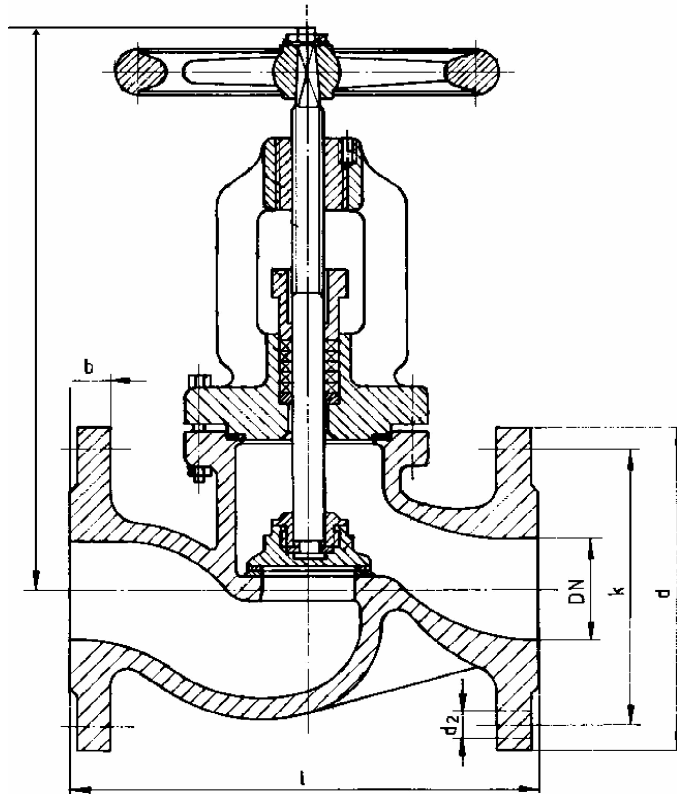

NOMINAL DIAMETAR DN	FLANGE				MAIN MEASURES		WEIGHT ~ kg	
	b	d	k±0, 2	DRILLING		l		h
				d ₂	n .			
15	18	95	65	14	4	130	195	5
20		105	75			150		6
25		115	85			160	7	
32		140	100			180	9	
40		150	110			200	250	11,5
50		165	125			230		15
65		185	145	18	8	290	283	20
80		200	160			310	305	30
100		220	180			350	345	39
125		250	210			400	400	65
150		22	285	22	12	480	440	99
200			340			295	600	530